

## 47. Title: A system for modulating a brushless DC motor

**Inventor:** Prof. Bhim Singh, Department of Electrical Engineering

**Key Words:** Ceiling fan, BLDC motor, Brushless DC motor, Power quality

**Domain:** Motors & Machines

Summary: A system to provide a permanent magnet brushless direct current motor drive for a brushless DC motor is developed. The BLDC motor drive controller estimates the position of the rotor of the BLDC motor, and a PFC converter controller controls the speed of the ceiling fan. The system solves power quality issues in the existing brushless direct current (BLDC) motor ceiling fan with a reduced power input of 3 to 4 W.

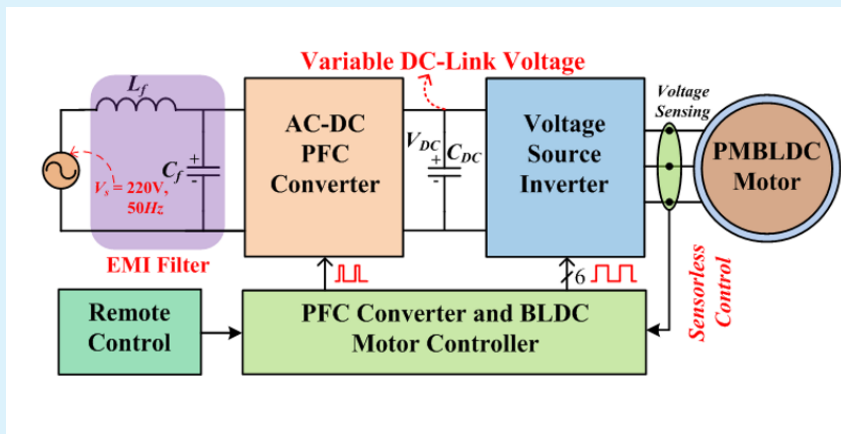

Diagram: Schematic representation of the system

### Advantages:

- » Improves the power quality (%THD- 2%, PF-0.998) as compared to existing
- » Reduces power input (around 3 to 4W)
- » Eliminates the sensing arrangement
- » Reduces the switching losses in the inverter

**Applications:** Low power application of BLDC motor, like ceiling fan, table fan, exhaust fan etc.

**Scale of Development:** A functional prototype system is developed and its performance is evaluated by testing in simulated environment for different values of input power.

**Technology Readiness Level:** 5

**IP Status:** Indian Patent Application 202111030548